

CI 45

Partitioning walls and interior doors

R
REYNAERS
aluminium

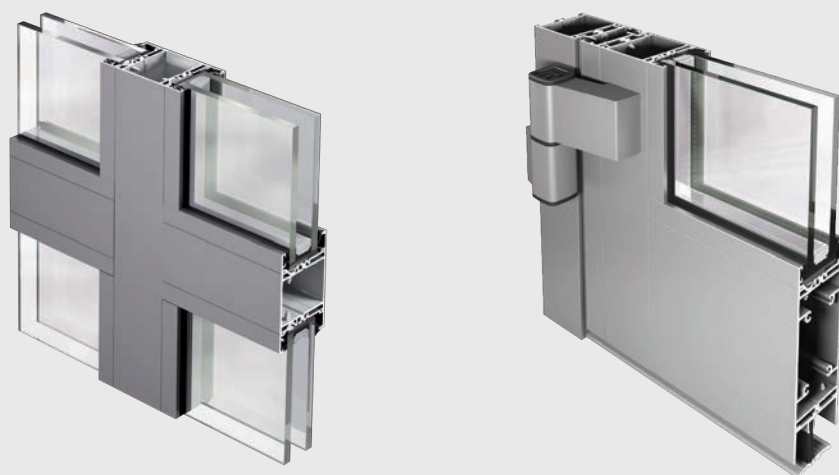

The CI 45 is a system of partitioning walls and interior doors mainly for office space arrangement. Its simplicity and a scope of offered solutions fulfils expectations of almost each user.

Simple fabrication and easy assembly enable to reduce time and cost of final product to a large extent.

The system is equipped with a special chamber in order to integrate office cabling (computer wiring, phone cables, electric cables) which effects the aesthetics.

The CI 45 is a modular system. The construction can be modified any time.



NEW DIMENSION OF PARTITIONING WALLS

INNOVATION AND AESTHETICS

FIXED ELEMENT

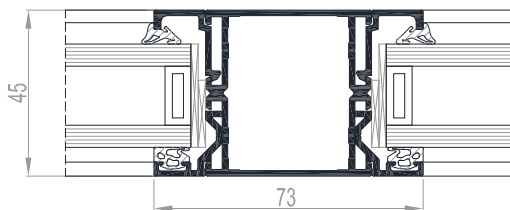

DOOR

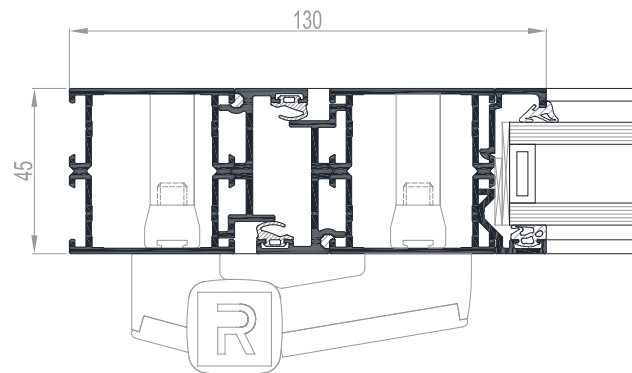

UNIVERSALITY

The major advantage of the CI 45 system is its universality. With scarcely 33 profiles it is possible to perform partitioning walls, swing doors, sliding doors, fully glazed doors, and double layer glazing wall of depth of 100 mm and 125 mm which are easily assembled with a plaster-cardboard wall.

The system is based on several basic profiles which after assembling together with adaptation profiles may become a frame, transom or door leaf.

The advantages resulting from the universality of the system:

- costs reduction owing to decrease of the amount of aluminium production waste
- reducing the number of articles in the warehouse
- simplification of order list
- simplified prefabrication

FUNCTIONALITY

The system of screen walls and doors is designed mainly for arranging office space. Apart from the standard features of the screen walls it offers additional solutions:

- double glazed walls with high acoustic insulation ($R_w=53$ dB)
- space between glazing can be used for internal sunblinds
- possibility of joining with a plaster wall of 75, 100, and 125 mm
- possibility of adjoining with a handrail RB 10
- possibility of installation of glass door vent
- there are available sliding doors manually operated
- a profile with the special chamber for integrated office cabling (computer wiring, phone cables, electric cables)



SIMPLICITY OF PRODUCTION

The CI 45 enables simple production process owing to the less complicated solution of the T-profile joint. The profile is cut at the straight angle and needs no milling. This way of treatment of profiles does not require any special instrumentation and therefore prefabrication of the construction at the place of assembly is possible with using proper portable saw, drill template, and standard tools.

MODULARITY

One of the advantages of the CI 45 system is a modularity of the solution. There is opportunity to modify existing construction any time, for example, by exchanging a stationary module to movable one (glass door vent). Such solution is a great opportunity for adaptation of rent office space.

SIMPLE ARRANGEMENT OF OFFICE SPACE

THE CHAMBER INTEGRATING OFFICE CABLING

DOUBLE LAYER GLAZING WALL - JOINT WITH PLASTER WALL (100MM)

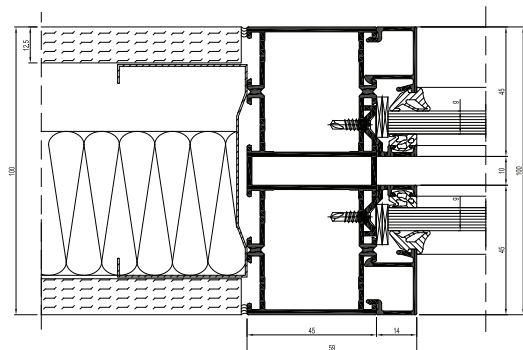
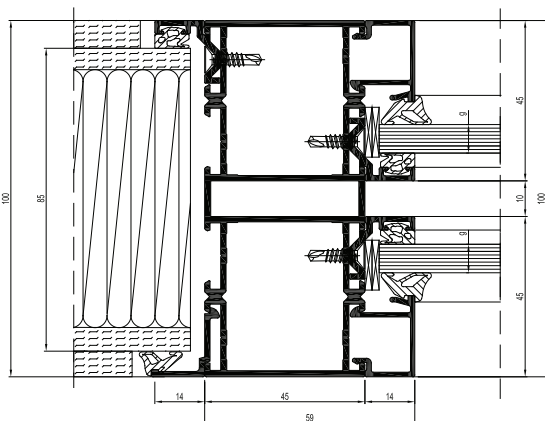

CI 45

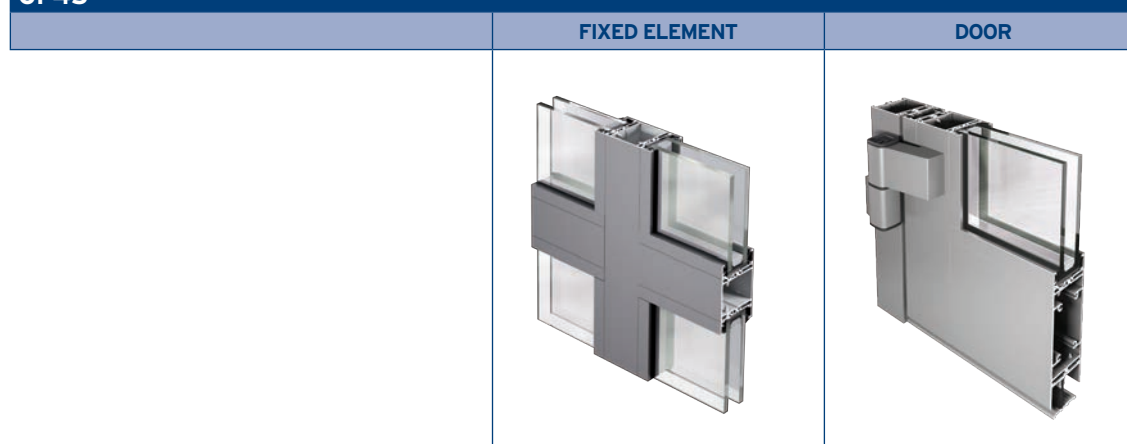

TECHNICAL CHARACTERISTICS

Min. visible outside width window	Frame	38mm
Min. visible width outward/ inward opening flush door	Frame	65mm
	Door leaf	79mm
Min. visible width T-profile		52mm
Overall system depth window	Frame	45mm (100mm ; 125mm)
Rebate height		14mm
Glass thickness		4mm - 30mm
Glazing method		EPDM gaskets

PERFORMANCES

COMFORT		
	Acoustic performance ⁽¹⁾ PN-EN 20140-3; PN-EN ISO 717	partitioning wall $R_w(C; C_{tr}) = 53(-2;-6)$ dB door $R_w(C; C_{tr}) = 48(-1;-2)$ dB
	Air tightness - door ⁽²⁾ PN-EN 1026; PN-EN 12207	class 2
	Wall resistance to horizontal load ⁽³⁾ PB LL-105/1/01-2001; PN-EN 12179	max. deflection $<H/400$ pressure difference ± 250 Pa or horizontal load of 1kN/m at height of 1,2m
	Door class with regard to conditions of exploitation ⁽⁴⁾ PN-EN 1192	class 2
	Resistance to multiple opening and closing doors ⁽⁵⁾ PN-EN 1191; PN-EN 12400	class 5
	Smoke resistance door ⁽⁶⁾ PN-EN 1634-3; PN-EN 13501-2	classes $S_{m,r}$, S_a

- (1) The sound reduction index (R_w) measures the capacity of sound reduction performance of the glass construction.
- (2) The air tightness test measures the volume of air that would pass a closed construction at a certain pressure difference with respect to door surface and rebate length.
- (3) Wall resistance to horizontal load is a measure of profiles stiffness on linear load (imitating pressure of the crowd) or air pressure defined by max. deflection of profiles.
- (4) Classes 1 to 4 determine possibility of applying doors in certain conditions of using space (class 2 - average conditions of utilization).
- (5) Classes 1 to 5 - resistance for cyclical loads resulting from opening and closing - parameter deciding on utilization of door in space of particular functional parameters (class 5 - 100,000 cycles, possible to apply as inside door in public sector buildings).
- (6) Smoke resistance determines that maximum air flow velocity passing through closed doors measured in ambient temperature class S_a and in temperature of 200°C class S_m at certain pressure of 50 Pa did not exceed 20m³/h for single door and 30 m³/h for double door.

